

SERIES **670, 675** **690, 695**

A unique feature of these clamps is the collet-type bushing that can be adjusted to eliminate plunger end movement after long, repeated usage. The plunger also has a flat which prevents lateral movement and permits offset piloting and holding.

The plunger is drilled and tapped for threaded spindles or custom fixturing.

A pre-load nut (PL) is optional. This adjustable nut can be used to cause the clamp to lock against itself when not under pressure and therefore prevent opening when mounted vertically. An optional spring hold-open device (S) is also available to prevent the clamp from falling closed. Spring clip covers (C) can be ordered which protect the mechanism from chips, shavings, etc. Available in two styles, Models 670 and 690 offer longer plunger travel than the shorter Models 675 and 695. All four models can be ordered with the handle position welded to optional base (B) at 90° increments - the 0° position being straight up vertically. Ball handles are standard on Models 670 and 675.

- Heavy-duty - high production clamp
- Adjustable collet-type bushing minimizes plunger end movement
- Pre-load nut optional (PL)
- Spring hold-open device optional (S)
- Designed for accurate repeatability
- Welded handle position optional when base accessory is ordered (B)
- Optional base assembly available for easy mounting (B)

Models 670-B-O, 675-B-O
Closed & Locked



Models 690-B-180-PL, 695-B-180-PL
Closed & Locked



Model Code & Ordering Information

Example: **670** - **B** - **PL** - **O** - **S** - **C**

Model No.	Base	Preload Option	Handle Angle Welded to Base	Hold-Open Option	Cover Option
670 675 690 695	B Includes mounting ring and base flange. Specify "R" option if only the ring is required.	PL	0° 90° 180° 270°	S	C

MANUAL CLAMPS

Heavy-Duty Plunger Action



DE-STA-CO
A DOVER RESOURCES COMPANY

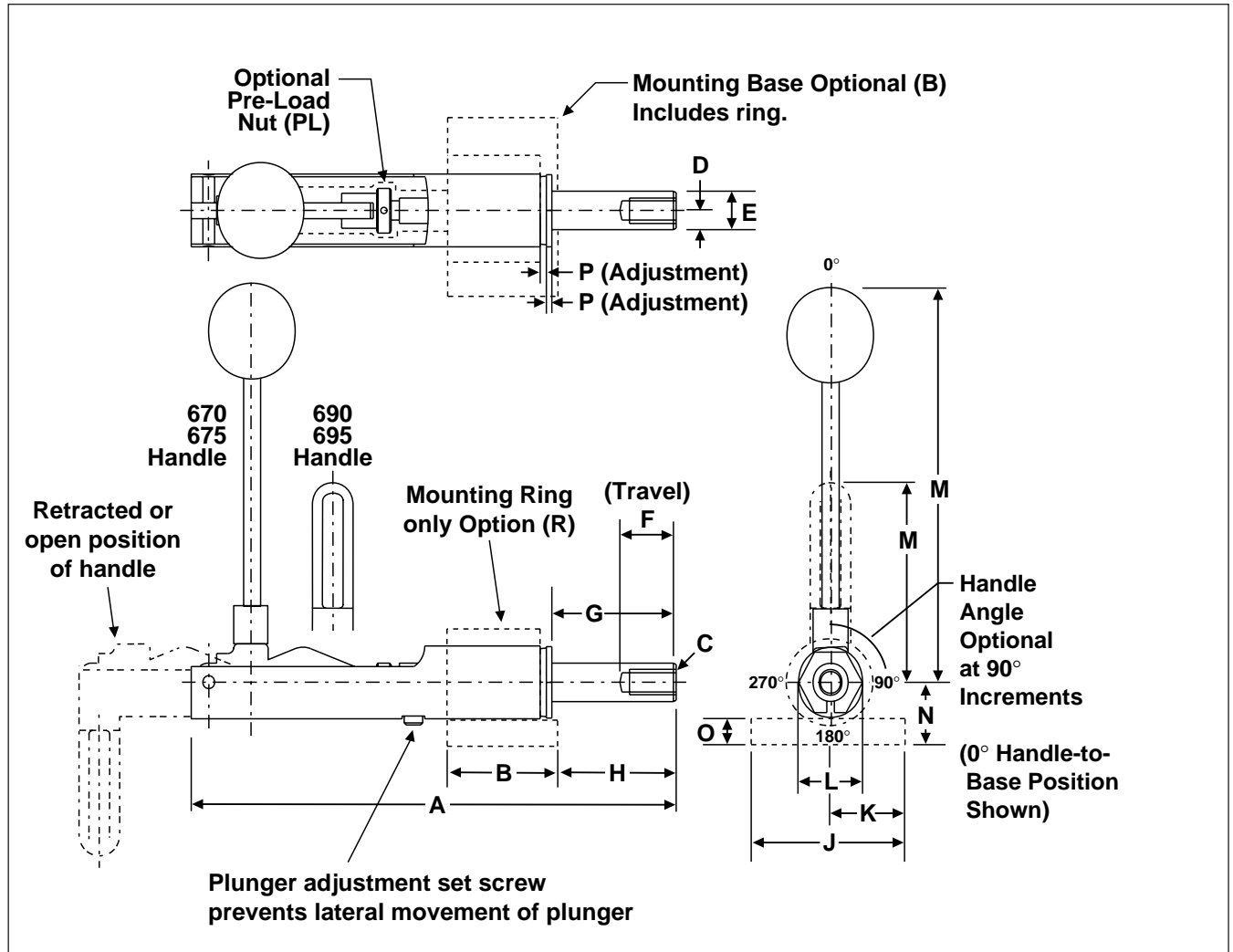

Model No.	EDP No.	Holding Capacity	Weight	Dimensions														
				A	B	C	D	E	F	G	H	J	K	L	M	N	O	P
670	56700	2500 lbs.	4 lbs. 6 oz.	10.50	2.25	1/2-13 Thd 1" Deep	.312 Ref.	.75	2.25	2.69	2.81	3.50	1.75	1.38	6.38	1.365 1.375	0.50	0.13
675	56750	2500 lbs.	3 lbs. 4 oz.	7.69	2.25	1/2-13 Thd 1" Deep	.312 Ref.	.75	1.13	1.50	1.63	3.50	1.75	1.38	6.38	1.365 1.375	0.50	0.13
690	56900	5000 lbs.	8 lbs. 6 oz.	13.31	3.00	5/8-11 Thd 1" Deep	.437 Ref.	1.00	3.00	3.38	3.44	4.00	2.00	1.75	4.75	1.625 1.615	0.50	0.13
695	56950	5000 lbs.	7 lbs. 4 oz.	9.44	3.00	5/8-11 Thd 1" Deep	.437 Ref.	1.00	1.50	1.88	1.94	4.00	2.00	1.75	4.75	1.625 1.615	0.50	0.13

670, 690 Long Plunger
675, 695 Short Plunger