

# MANUAL CLAMPS

## Carver Buttress Style

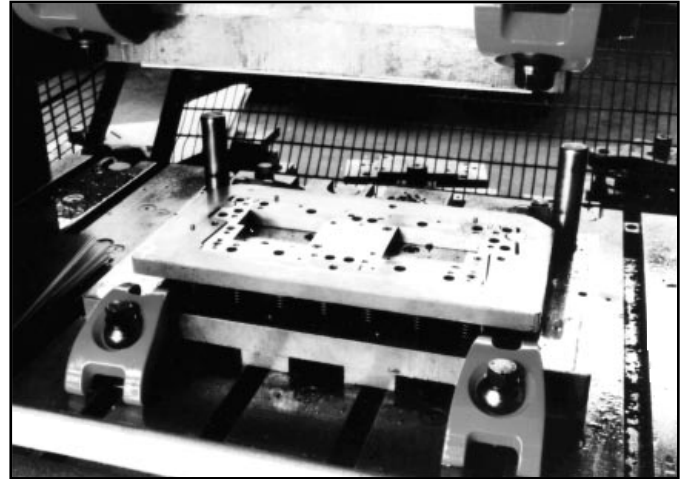

These workholding clamps are designed for use on thin or low-profile workpieces replacing ordinary strap clamps. They feature a self-aligning swiveling pivot which allows the tightening bolt to always remain vertical, preventing any side forces. The two-point contact offered by Models T614-0 and T614-1 also provides greater stability to the workpiece. The Buttress Clamps are available in three capacities from 2,875 lbs. to 17,600 lbs. holding capacity.

Ideally suited for manual die clamping. Eliminates the need for step blocks or riser blocks.

Model No.	Holding Capacity	Working Height Range (H)
T614-0	2875 lbs.	0 - 1.75"
T614-1	13750 lbs.	0 - 2.25"
T614-2	17600 lbs.	0 - 3.00"

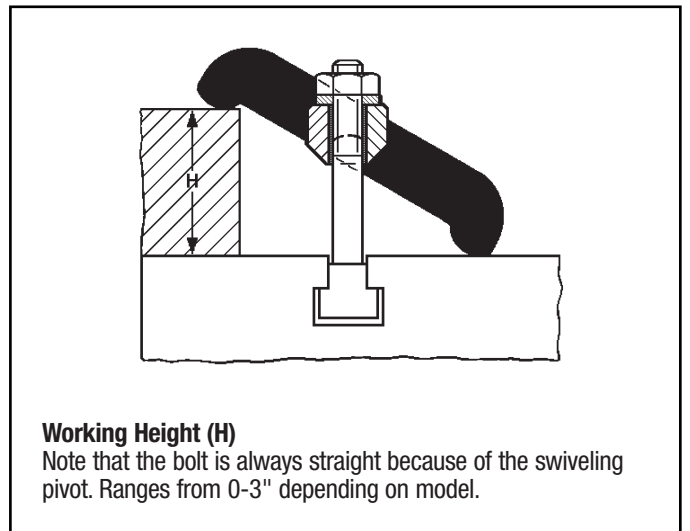

**56140**  
Model T614-0



**56141**  
Model T614-1



**56142**  
Model T614-2

