

MANUAL CLAMPS

Heavy-Duty Hold-Down and Straight-Line Action



MODEL 517

Model 517, which can provide up to 600 lbs. force, is made from C-1008 or C-1010 low carbon, cold-rolled steel and has a black oxide finish. Features extra clearance under hold-down bar. Hardened and ground pivot pins can be replaced. Hold-down bar is forged and can be cut or welded to suit fixturing or tooling needs.

55170
Model 517
Solid Bar
Weldable Base

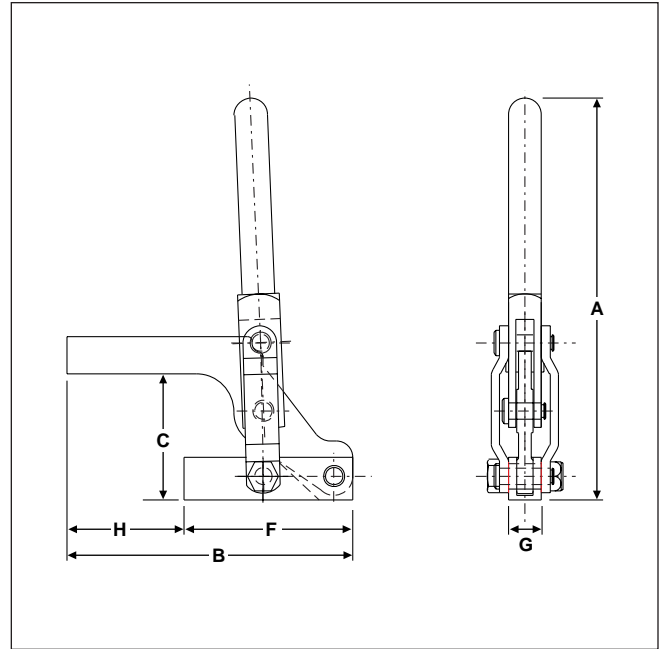
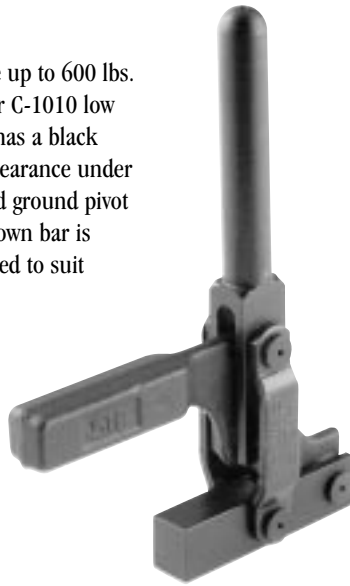

Model No.	EDP No.	Holding Capacity	Weight	Handle Moves	Bar Opens	Dimensions					
						A	B	C	F	G	H
517	55170	600 lbs.	.81 lbs.	225°	135°	6.00	4.25	1.88	2.50	.50	1.75

MODEL 617

Compact Model 617 clamp has block-style body which can be machined or welded for mounting. Greater holding capacity than normal for clamps of this size. Plunger bushing makes for smooth action. Tapped for 5/16-18 spindle. Handle can be modified for special applications. Made from C-1008 or C-1010 low carbon, cold-rolled steel. Black oxide finish. Replaceable hardened and ground pivot pins.

56170
Model 617

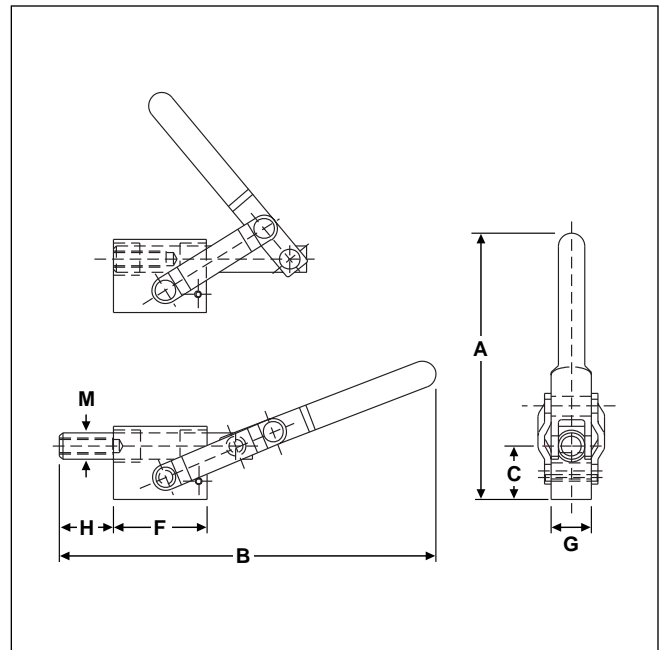

Model No.	EDP No.	Holding Capacity	Weight	Plunger Travel	Plunger Thread	Dimensions						
						A	B	C	F	G	H	M
617	56170	2000 lbs.	.88 lbs.	1.00"	5/16 - 18	5.00	7.00	1.00	1.75	.75	1.00	.50