

# Toggle-Lock Plus™: DE-STA-CO's Clamp Line with Locking Release Lever Action

We have taken several of our more popular toggle clamps and have added a locking release lever for improved safety. The locking release lever helps ensure that the over-center locking condition is maintained. In order to open each clamp, the locking lever must first be released.

The addition of the Toggle-Lock Plus™ product line expands the range of applications where DE-STA-CO clamps can be used. If a clamp application warrants concerns over accidental clamp opening, severe stresses or vibrations on the clamps, or overhead installations, then the Toggle-Lock Plus™ is the right clamp for the job.

Look for our new Heavy-Duty Toggle-Lock Plus™ Production Clamps on page 77.

## MODELS **207-SA, 207-UA** **210-SA, 210-UA**

These clamps are unique in that they lock with the aid of the release lever in both the clamped and unclamped position.

These items offer several safety considerations:

- Ergonomic Handle Grips
- Safety Link
- Positive Locking Release Lever

Bolt retainer supplied with solid bar Models 207-SA (207105) and 210-SA (210114), and flanged washers supplied with "U" bar Models 207-UA (507107) and 210-UA (235106). Spindle assemblies are not included.



**52108**  
Model 210-UA  
"U" Bar  
Flanged Base

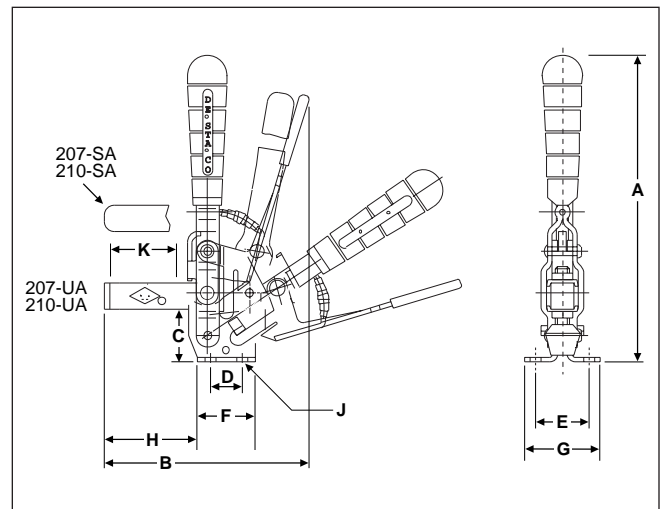

**52071**  
Model 207-SA  
Solid Bar  
Flanged Base



**52078**  
Model 207-UA  
"U" Bar  
Flanged Base



**52104**  
Model 210-SA  
Solid Bar  
Flanged Base



Model No.	EDP No.	Holding Capacity	Weight	Bar Opens	Dimensions									
					A	B	C	D	E	F	G	H	J	K
207-SA	52071	500 lbs.	1.00 lb.	100°	7.13	4.50	1.25	.75	1.28	1.38	1.80	2.22	.25	—
207-UA	52078	375 lbs.	1.00 lb.	100°	7.13	4.50	1.25	.75	1.28	1.38	1.80	2.22	.25	1.30
210-SA	52104	750 lbs.	1.60 lbs.	103°	8.00	6.61	1.68	1.25	1.75	1.89	2.50	3.56	.33	—
210-UA	52108	600 lbs.	1.60 lbs.	103°	8.00	6.68	1.68	1.25	1.75	1.89	2.50	3.66	.33	2.41